



Lo-Pro Ready Van & Ready Van II

Expect More Choices and Standard Features with Ready Van



EXCLUSIVE TRIPLE PROTECTION

- 1** A40-A60 Coating Weight Steel
- 2** E-Coat Primer
- 3** Powder Coat Finish



Shown with optional equipment

Ready Van

DEPENDABLE | DURABLE | RUGGED | VERSATILE



Manufactured With Confidence

- ENCLOSED work space with convenient compartments
- CAB ACCESS with access door in front bulkhead
- EXCLUSIVE Dual-Pro® Seal System with patented hidden hinges
- DURABLE stainless steel rotary locks
- FITS In most garages



Unmatched standard features; an enclosed work space; plus secure, convenient outside compartments.

Reading's Lo-Pro Ready Van and Ready Van II just keep getting better! An impressive list of standard features makes these bodies the premier choice for upfitting your cutaway chassis.

Options



Latch-Matic® keyless entry and locking system simultaneously locks or unlocks the side compartment doors and rear cargo doors. Audible alarm feature also included



Compartment and cargo area lighting are automatically activated with Latch-Matic® keyless remote controller



Extend-a-Shelf™ Drawers with Grab Handles A 250-lb. capacity ball bearing shelf unit. Consists of 3 shelves with handles that permit easy operation of drawers and help secure drawers in place when compartment door is closed



Shown with optional equipment



Lo-Pro Ready Van will fit in most garages, allowing for indoor security.

The Lo-Pro is a single wheel variant of Reading's popular Ready Van in a more compact size; (132"x86"). The Lo-Pro Ready Van offers a generous 54"x52-3/4" rear cargo opening, secure outside storage compartments, plus an enclosed workspace. Two windows on rear cargo doors are standard and equipped with metal security protection.

The Ready Van II has the same standard features as the Lo-Pro Ready Van. Designed for dual wheel cutaway chassis, it also features an attractive radius contour on the front bulkhead. The Ready Van II is a 132" body and is available with either a 64" or 74" interior height. Two windows (equipped with metal security protection) on rear cargo doors are standard.



Aluma-Fill® Aluminum fuel fill receptacle protects truck body from accidental nicks and scratches



Rectangular Tail Lights Provides modern look and are leak resistant



Stainless Steel Paddle Handle with no exposed fasteners. Attractive appearance and rust resistant. Features a double bitted high quality locking cylinder, adjustable striker pins and an O-ring seal to prevent water intrusion



Pooched Bumper White Powder Coated steel. Pooched design provides slip resistant step surface



Patented Hidden Hinges Industry exclusive overlapping door construction resists forcible entry. Robust, concealed hinge design provides protection against corrosion without requiring frequent lubrication or maintenance. Fully adjustable and easily replaced without damage to body or door

Galvanized Shelves With 2" dividers for more small items storage. Full access between all vertical compartments for longer tool storage



Nitrogen Strut Door Holders All vertical compartment doors are equipped with nitrogen strut door holders. Internal dampeners control the opening and closing of doors



Heavy-Duty Compartment Doors 18 Gauge outer door skin with double-paneled construction and internal reinforcement make these the thickest and strongest doors in the industry

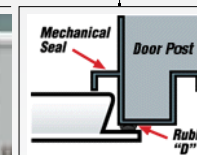

Exclusive Dual-Pro® Seal System Patented design increases clear door openings in every compartment of the body. Large, automotive quality bubble-type seal and mechanical seal provide a dual line of defense against weather

Dimensional Data

LO-PRO READY VAN

Model	Approx. Weight	Chassis	Cab-to-Axle	Approximate Compartment Clear Door Openings					
				A	B	C	D	E	F
CV57-132AP	2500 lbs.	Chevy & GMC Cutaway	80"	29"x35-1/2"	16-1/2"x35-1/2"	13"x48-1/2"	24-1/4"x35-1/2"	6-3/8"x8-3/16"	13"x68-1/2"
FV57-132AP	2500 lbs.	Ford Cutaway	80"	29"x35-1/2"	16-1/2"x35-1/2"	13"x48-1/2"	24-1/4"x35-1/2"	6-3/8"x8-3/16"	13"x68-1/2"

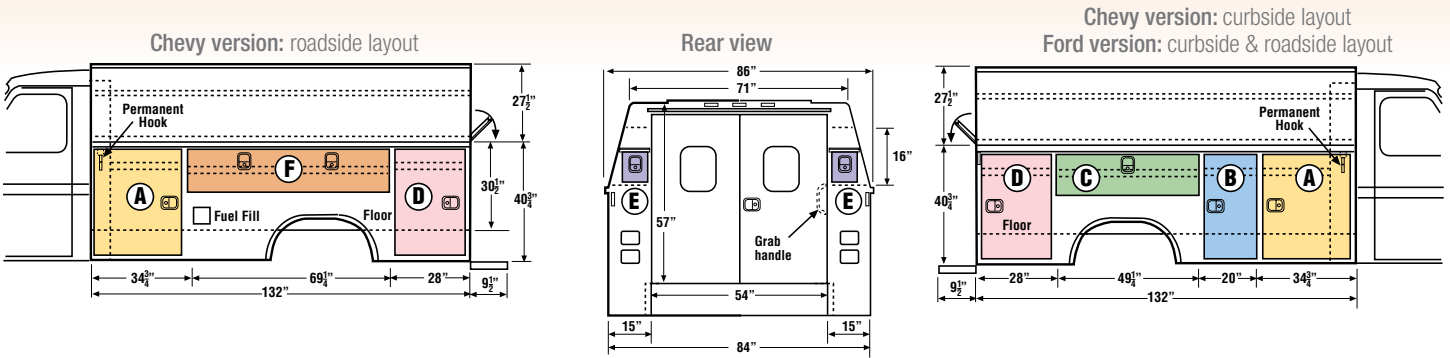

Standard Shelf & Divider Equipment: All shelves adjustable and/or removable with all dividers removable and adjustable. One shelf in each vertical and horizontal compartment (40) dividers.

READY VAN II

Model	Approx. Weight	Chassis	Cab-to-Axle	Approximate Compartment Clear Door Openings					
				A	B	C	D	E	F
CV64-132AP	2700 lbs.	Chevy & GMC Cutaway	80"	29"x35-1/2"	16-1/2"x35-1/2"	13"x48-1/2"	24-1/4"x35-1/2"	6-3/8"x8-3/16"	13"x68-1/2"
CV74-132AP	2798 lbs.								
FV64-132AP	2700 lbs.	Ford Cutaway	80"	29"x35-1/2"	16-1/2"x35-1/2"	13"x48-1/2"	24-1/4"x35-1/2"	6-3/8"x8-3/16"	13"x68-1/2"
FV74-132AP	2798 lbs.								

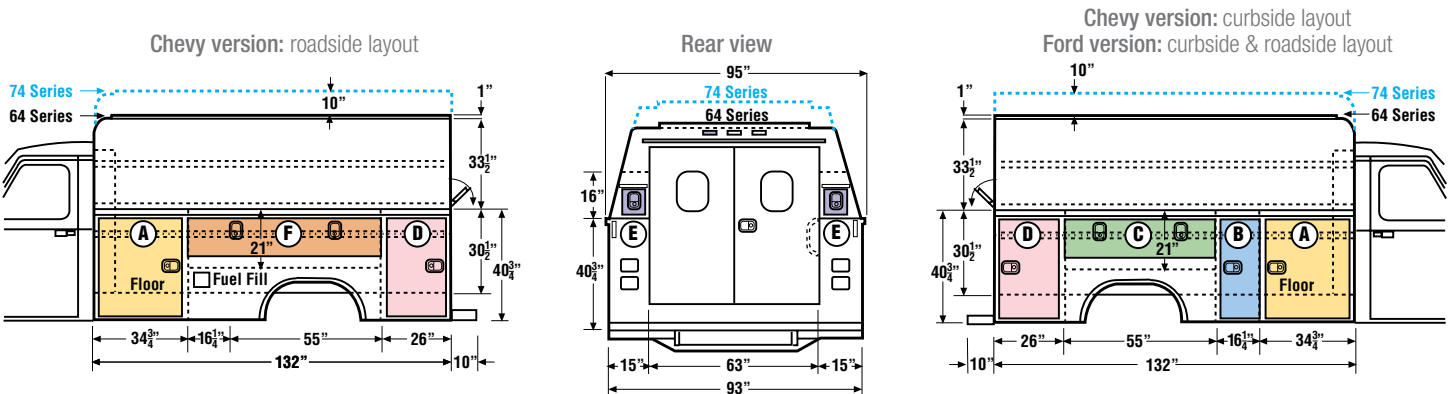

Standard Shelf & Divider Equipment: All shelves adjustable and/or removable with all dividers removable and adjustable. One shelf in each vertical and horizontal compartment (40) dividers.

Optional Accessories



- Steel overhead ladder racks
- E-Z slide™ and Grip-n-Glide® drawer units



Locations
 Abington, PA
 Atlanta, GA
 Bowmansville, PA

Cleveland, OH
 Clinton, MD
 Columbus, OH
 Denver, PA

LaGrange, TX
 Louisville, KY
 Pontiac, MI
 Portland, OR

Reading, PA
 Seneca, PA
 Suffolk, VA
 Tampa, FL

SOLD AND SERVICED LOCALLY BY

All dimensions subject to plus or minus tolerance of 1/4" and all dimensions and specifications are subject to change without notice. Some items displayed in photographs are optional. Alumina-Fill, Alumina-Chock, Dual-Pro, Extend-A-Shelf, Grip-n-Glide, Latch-Matic, Marauder, Reading, Redi-Dek, Rhino Linings, Rugged American, S.M.A.R.T. Racks, Spacemaker, Tool-Mates, and TUFF STUFF are registered trademarks of The Reading Group, LLC in the United States and some foreign countries. The Reading kangaroo is a trademarked image and may not be reproduced or used without express permission from The Reading Group.